

Data Sheet

D1 High Power Open Circuit Pumps

130/145/193/260 cm³



For more than 40 years, Danfoss has been developing state-of-the-art components and systems for mobile machinery used in off-highway operations around the world. We have become a preferred supplier by offering the best of what really matters: The hardware inside your vehicle application.

D1 - our new generation of servo-controlled high power open circuit pump. It is designed for quality and reliability and offers a wide variety of control options, greater total efficiency, and easy installation

The D1 pump is well suited for heavy duty applications: Concrete machinery, Mining machinery, Crane, Drilling machinery, Marine and Off-shore machinery, etc.

The D1 is PLUS+1[®] Compliant. PLUS+1[®] allows you to rapidly develop and customize electronic machine control. It opens up the future by combining machine controls and diagnostics in an integrated operating network.

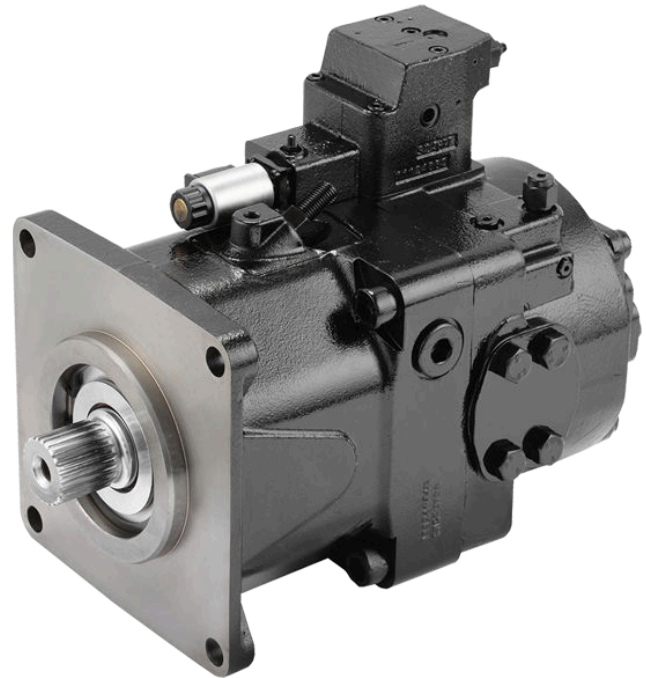

Features

Designed for quality and reliability

- Proven and optimized 9 piston rotating group
- Angled bore cylinderblock design improves self-priming capability
- The spherical valve plate and cylinderblock surface provide stable cylinderblock rotation, thus achieve high efficiency

Installation and packaging benefits

- Mainstream installation
- Standardized connector interface
- High power density

Expanded functionality

- Integral charge pump option allows the pump to run with higher speed
- PLUS+1[®] compliant control
- Full power through drive capability
- The electric displacement control features with manual override function for diagnosis

Control options

- TPE2/TPE5 : Mechanical power control + Pressure compensated control + Electric displacement control
- TPSN : Mechanical power control + Pressure compensated control + Load sensing control
- ENSN : Electric power control + Load sensing control
- NPSN : Pressure compensated control + Load sensing control

- NPNN : Pressure compensated control
- TPHN : Mechanical power control + Pressure compensated control + Hydraulic displacement control
- NNES : Electric displacement control + Load sensing control

Comprehensive technical literature online at powersolutions.danfoss.com

Technical Specifications

Features		Unit	130/145 (W/O Charge Pump)	130/145 (W/ Charge Pump)	193 (W/ Charge Pump)	260 (W/ Charge Pump)
Displacement		cm ³	130/145	130/145	193	260
Weight (approx.)		kg	68	74	106	141
Input Speed	Rated	min ⁻¹	2200	2500	2500	2300
	Max.		2500	2500	2500	2300
Theoretical Flow		l/min	273/319	325/363	483	598
System Pressure	Max. Working Pressure*	bar	350	350	350	350
	Max. Pressure		400	400	400	400
Inlet Pressure (Abs)	Min.	bar	0.8	0.6	0.6	0.6
	Max.	bar	30	2	2	2
Case Pressure (Abs)	Max.	bar	2	2	2	2

* Applied pressures above maximum working pressure requires Danfoss application approval.

Schematics/Dimensions (mm)

For other controls. please see D1 Technical Information, L1426007

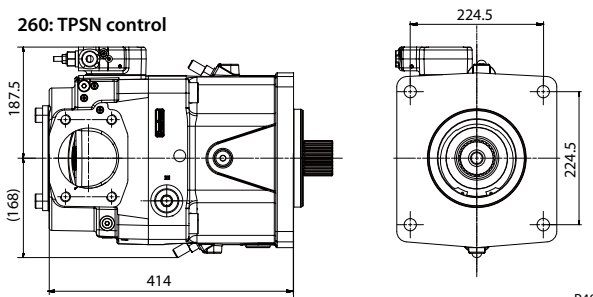
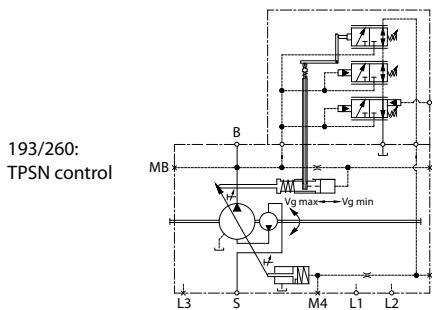
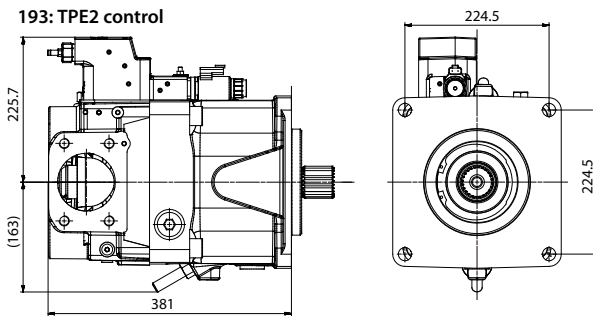
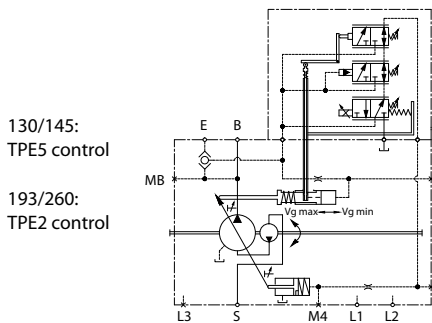
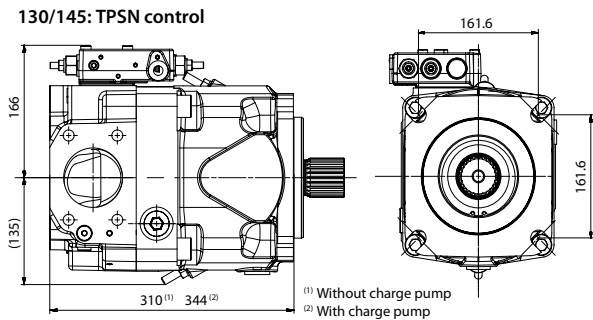
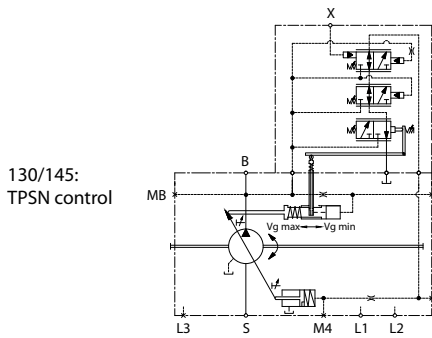

P400420

Danfoss can accept no responsibility for possible errors in catalogues, brochures and other printed material. Danfoss reserves the right to alter its products without notice. This also applies to products already on order provided that such alterations can be made without changes being necessary in specifications already agreed. All trademarks in this material are property of the respective companies. Danfoss and the Danfoss logotype are trademarks of Danfoss A/S. All rights reserved.