

2 MODEL CODE for OPTIONAL SPOOLS - refer to section 1 for valve model code and options

DHZO	-	TES	-	SP	-	NP	-	0	73 - V9	/	*	/	*	/	*
-------------	---	------------	---	-----------	---	-----------	---	----------	----------------	---	----------	---	----------	---	----------

Configuration, spool type and size:

73-Q5

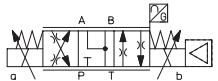

73-Q5/B

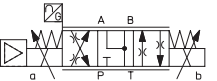

73-V9

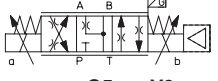

73-V9/B

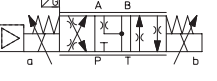

Spool size: **Q5** **V9**

DHZO = 30 30

DKZOR = 75 75

Nominal flow (l/min) at Δp 10 bar P-T

Q5

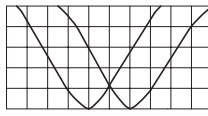

For alternate P/Q control see section 9, diagram 16

V9

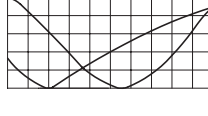

For alternate P/Q control of injection cycle in plastic machinery see section 9, diagram 17

3 GENERAL NOTES

DHZO-TEB, TES and DKZOR-TEB, TES proportional valves are CE marked according to the applicable Directives (e.g. Immunity/Emission EMC Directive and Low Voltage Directive). Installation, wirings and start-up procedures must be performed according to the general prescriptions shown in table F003 and in the installation notes supplied with relevant components. The electrical signals of the valve (e.g. monitor signals) must not be directly used to activate safety functions, or components, as prescribed by the European standards (Safety requirements of fluid technology systems and components-hydraulics, EN-982).

4 ALTERNATED P/Q CONTROLS - only for **TES** with valve configuration **53** and **73**

S* options add the closed loop control of pressure (**SP**) or force (**SF** and **SL**) to the basic functions of proportional directional valves flow regulation. A dedicated algorithm alternates pressure (force) depending on the actual hydraulic system conditions. An additional connector is available for transducers to be interfaced to the valve's driver (1 pressure transducer for SP, 2 pressure transducers for SF or 1 load cell for SL). Main 12 pin connector is the same as /Z option plus two analog signals specific for the pressure (force) control. The alternated P/Q controls are specific for valve configuration 73, optional spools type Q5 and V9 recommended, see section 2. For detailed information and connector wiring of options SP, SF, SL see tech table **GS212**.

5 FIELDBUS - only for **TES**

Fieldbus allows the direct communication of the proportional valve with machine control unit for digital reference signal, diagnostics and settings of functional parameters. Analog reference signal remain available on the main connector for quick commissioning and maintenance. For detailed information about fieldbus features and specification see tech table **GS510**.

6 MAIN CHARACTERISTICS - based on mineral oil ISO VG 46 at 50 °C

Assembly position	Any position			
Subplate surface finishing	Roughness index, Ra 0,4 flatness ratio 0,01/100 (ISO 1101)			
MTTFd values according to EN ISO 13849	150 years, see technical table P007			
Ambient temperature range	standard = -20°C ÷ +60°C		/BT option = -40°C ÷ +60°C	
Storage temperature range	standard = -20°C ÷ +70°C		/BT option = -40°C ÷ +70°C	
Coil resistance R at 20°C	DHZO = 3 ÷ 3,3 Ω		DKZOR = 3,8 ÷ 4,1 Ω	
Max. solenoid current	2,6 A			
Max. power	50 Watt			
Insulation class	H (180°) Due to the occurring surface temperatures of the solenoid coils, the European standards ISO 13732-1 and EN 982 must be taken into account			
Protection degree to DIN EN60529	IP66/67 with mating connector			
Tropicalization	Tropical coating on electronics PCB			
Duty factor	Continuous rating (ED=100%)			
EMC, climate and mechanical load	See technical table G004			
Communication interface	USB Atos ASCII coding	CANopen EN50325-4 + DS408	PROFIBUS DP EN50170-2/IEC61158	EtherCAT, POWERLINK EtherNet/IP IEC 61158
Communication physical layer	not insulated USB 2.0 + USB OTG	optical insulated CAN ISO11898	optical insulated RS485	Fast Ethernet, insulated 100 Base TX

Valve model	DHZO						DKZOR		
Pressure limits [bar]	ports P, A, B = 350; T = 210 (250 with external drain /Y); Y = 10						ports P, A, B = 315; T = 210 (250 with external drain /Y); Y = 10		
Spool type	L14	L1	S2	L3,S3,D3	L5,S5,D5	Q5,V9	L3,S3,D3	L5,S5,D5	Q5,V9
Nominal flow [l/min] (1)									
Δp= 10 bar	1	4,5	8	18	28	30	45	75	75
Δp P-T Δp= 30 bar	1,7	8	14	30	50	52	80	130	130
max Δp= 70 bar	2,6	12	21	45	75	80	120	170	170
permissible flow (2)	4	18	30	50	80	80	130	180	180
Response time [ms] (0-100% step signal) (3)	≤ 15						≤ 20		
Leakage [cm³]	<30 (at p = 100 bar); <135 (at p = 350 bar)						<80 (at p = 100 bar); <600 (at p = 315 bar)		
Hysteresis	≤ 0,2 [% of max regulation]								
Repeatability	± 0,1 [% of max regulation]								
Thermal drift	zero point displacement < 1% at ΔT = 40°C								

Notes: above performance data refer to valves coupled with Atos electronic drivers, see section 8
(1) for different Δp, the max flow is in accordance to the diagrams in section 9.2 **(2)** see detailed diagrams in section 9.3
(3) see detailed diagrams in section 9.4

7 SEALS AND HYDRAULIC FLUID - for other fluids not included in below table, consult our technical office

Seals, recommended fluid temperature	NBR seals (standard) = -20°C ÷ +60°C, with HFC hydraulic fluids = -20°C ÷ +50°C FKM seals (/PE option) = -20°C ÷ +80°C HNBR seals (/BT option) = -40°C ÷ +60°C, with HFC hydraulic fluids = -40°C ÷ +50°C		
Recommended viscosity	20 ÷ 100 mm ² /s - max allowed range 15 ÷ 380 mm ² /s		
Fluid contamination class	ISO 4406 class 20/18/15 NAS 1638 class 9, in line filters of 10 µm (β ₁₀ ≥ 75 recommended)		
Hydraulic fluid	Suitable seals type	Classification	Ref. Standard
Mineral oils	NBR, FKM, HNBR	HL, HLP, HLPD, HVL, HVLDP	DIN 51524
Flame resistant without water	FKM	HFDU, HFDR	ISO 12922
Flame resistant with water	NBR, HNBR	HFC	

8 ELECTRONIC DRIVERS

Valve model	TEB	TES	TES-SP, SF, SL
Drivers model	E-RI-TEB-N	E-RI-TES-N	E-RI-TES-S
Type	Digital		
Format	Integral to valve		
Data sheet	GS208	GS210	GS212

Note: for main and communication connector see sections [13](#), [14](#)

9 DIAGRAMS - based on mineral oil ISO VG 46 at 50 °C

9.1 Regulation diagrams - values measure at Δp 30 bar P-T

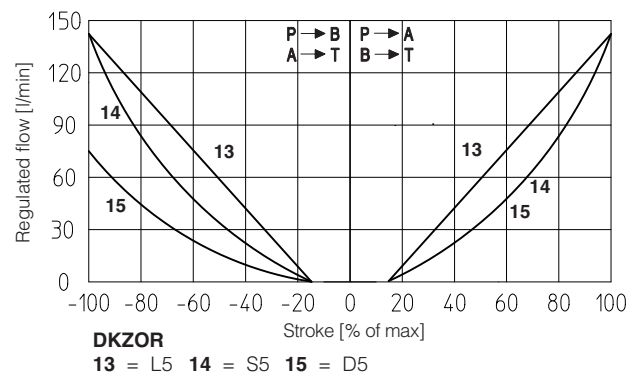
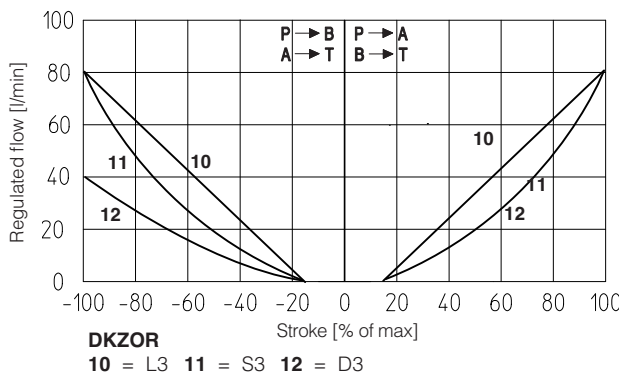
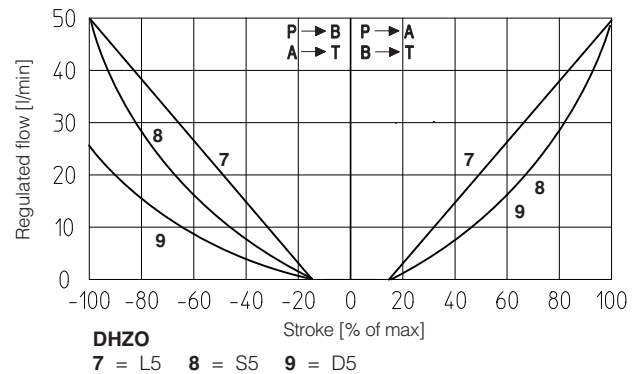
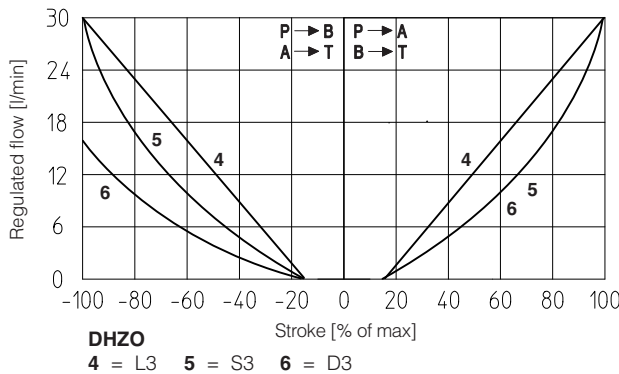
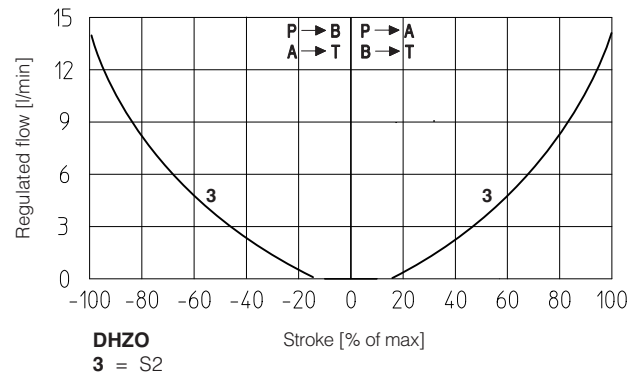
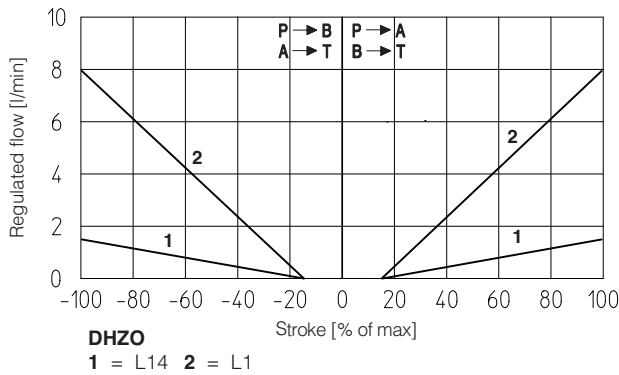

Note:

Hydraulic configuration vs. reference signal for configurations 71, 72 and 73 (standard and option /B)

Reference signal $\left. \begin{matrix} 0 \div +10 \text{ V} \\ 12 \div 20 \text{ mA} \end{matrix} \right\} P \rightarrow A / B \rightarrow T$ Reference signal $\left. \begin{matrix} 0 \div -10 \text{ V} \\ 12 \div 4 \text{ mA} \end{matrix} \right\} P \rightarrow B / A \rightarrow T$

16 = linear spool **Q5**

Q5 spool type is specific for alternate P/Q controls in combination with S* option of digital integral drivers (see tech table **GS212**). It allows to control the pressure in A port or B port and it provides a safety central position (A-T/B-T) to depressurize the actuator chambers.

The strong meter-in characteristic makes the spool suitable for both pressure control and motion regulations in several applications.

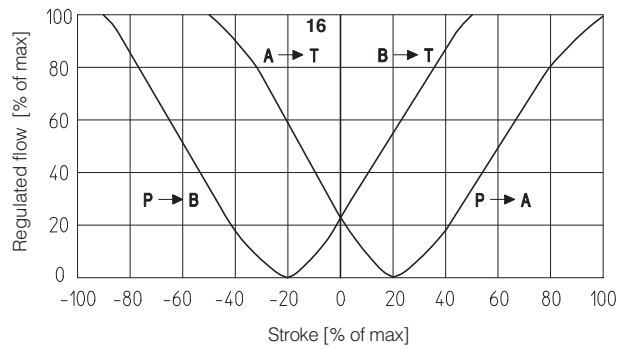

17 = differential - progressive spool **V9**

V9 spool type is specific for alternate P/Q controls in combination with S* option of digital integral drivers (see tech table **GS212**) or Z-ME-KZ/GI axis card (see tech table **G345**). This spool is specially designed to manage the whole injection cycle in plastic machinery, thanks to the following specific features:

- strong meter-in characteristic to allow the pressure control in A port during the holding pressure (P-A) and the plasticizing (A-T) phases
- safety central position (A-T/B-T) to depressurize the actuator chambers
- large A-T and B-T flow capability, required during the plasticizing phase, to discharge big volumes from high differential injection cylinders with low pressure drops and permitting the contemporary oil suction from tank

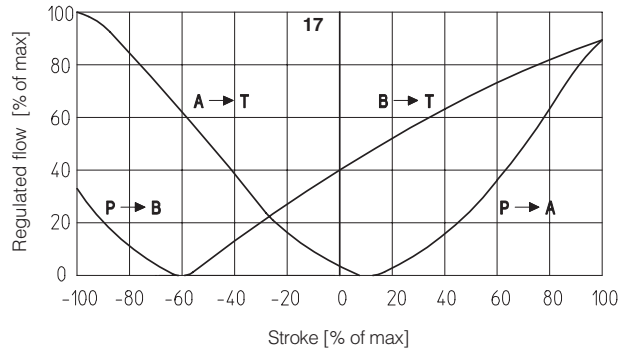

9.2 Flow / Δp diagrams

stated at 100% of valve stroke

DHZO

- 1 = spool L14
- 2 = spool L1
- 3 = spool S2
- 4 = spool L3, S3, D3
- 5 = spool L5, S5, D5, V9

DKZOR

- 6 = spool S3, L3, D3
- 7 = spool S5, L5, D5, V9

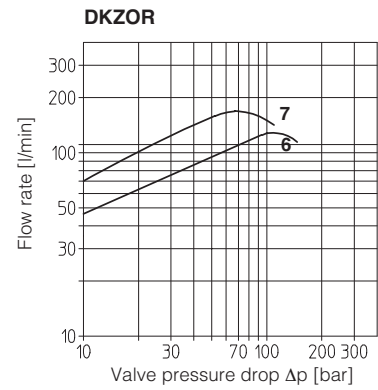
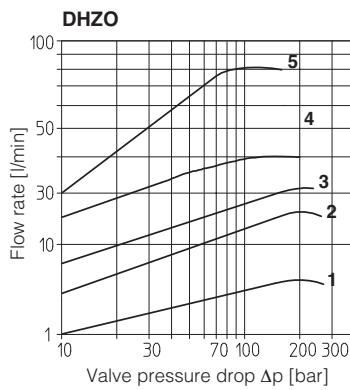

9.3 Operating limits

DHZO

- 1 = spool L14
- 2 = spool L1
- 3 = spool S2
- 4 = spool L3, S3, D3
- 5 = spool L5, S5, D5, V9

DKZOR

- 6 = spool S3, L3, D3
- 7 = spool S5, L5, D5, V9

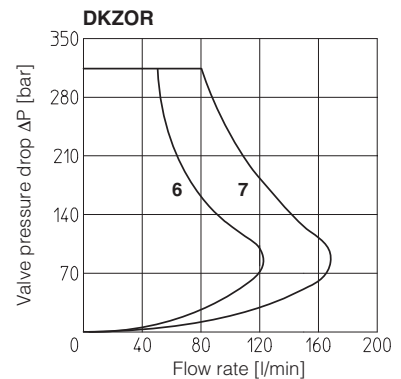
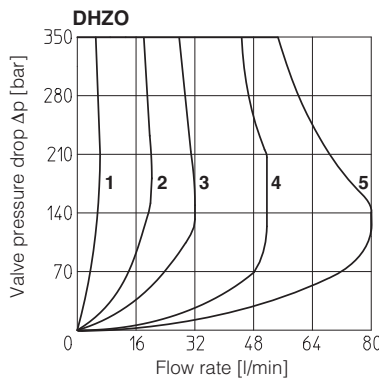

9.4 Response time

The response times in below diagrams are measured at different steps of the reference input signal. They have to be considered as average values. For the valves with digital electronics the dynamics performances can be optimized by setting the internal software parameters.

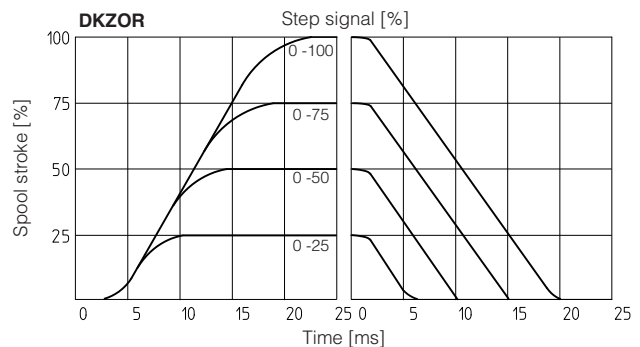
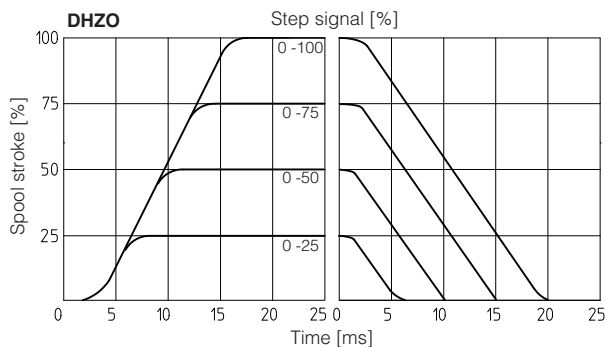

9.5 Bode diagrams

- 1 = 10% ↔ 90% nominal stroke
- 2 = 50% ± 5% nominal stroke

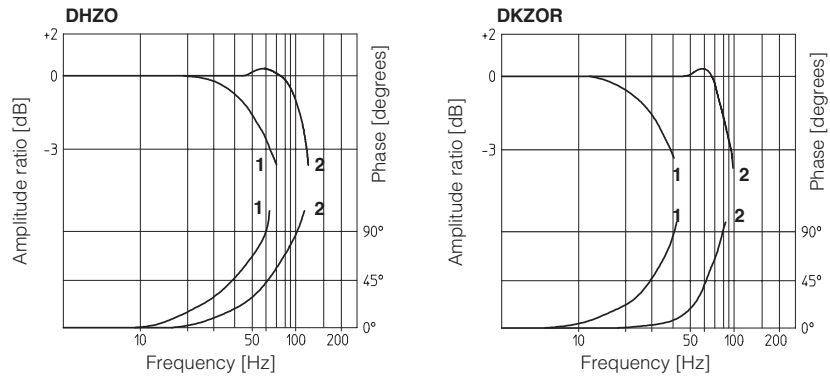

9.6 Operation as throttle valve

Single solenoid valves configuration
51 and 53 can be used as simple
throttle valves:
Pmax = 250 bar (option /Y advisable)

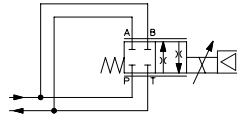

Max flow $\Delta p = 30 \text{ bar}$ [l/min]	SPOOL TYPE				
	L14	L1	S2	L3 S3	L5 S5
DHZO	4	16	28	60	100
DKZOR	-	-	-	160	260

10 HYDRAULIC OPTIONS

10.1 Option /B

Solenoid, integral electronics and position transducer at side of port A of the main stage. For hydraulic configuration vs reference signal, see section 9.1

10.2 Option /Y

External drain advisable when the valve is used in double flow path, see section 9.6. Option /Y is mandatory if the pressure in port T exceeds 210 bar.

11 ELECTRONIC OPTIONS

Standard driver execution provides on the 7 pin main connector:

Power supply - 24 VDC must be appropriately stabilized or rectified and filtered; 2.5 A fuse time lag is required in series to each driver power supply. Apply at least a 10000 $\mu\text{F}/40 \text{ V}$ capacitance to single phase rectifiers or a 4700 $\mu\text{F}/40 \text{ V}$ capacitance to three phase rectifiers

Reference input signal - analog differential input with $\pm 10 \text{ VDC}$ nominal range (pin D, E), proportional to desired valve spool position

Monitor output signal - analog output signal proportional to the actual valve's spool position with $\pm 10 \text{ VDC}$ nominal range

Note: a minimum booting time between 400 and 800 ms has been considered from the driver energizing with the 24 Vdc power supply before the valve has been ready to operate. During this time the current to the valve coils is switched to zero.

11.1 Option /F

It provides a Fault output signal in place of the Monitor output signal, to indicate fault conditions of the driver (cable interruption of spool transducers or reference signal - for /I option): Fault presence corresponds to 0 VDC, normal working corresponds to 24 VDC

11.2 Option /I

It provides 4 ÷ 20 mA current reference and monitor signals, instead of the standard $\pm 10 \text{ V}$.

Input signal can be reconfigured via software selecting between voltage and current, within a maximum range of $\pm 10 \text{ V}$ or $\pm 20 \text{ mA}$.

It is normally used in case of long distance between the machine control unit and the valve or where the reference signal can be affected by electrical noise; the valve functioning is disabled in case of reference signal cable breakage.

11.3 Option /Q

To enable the driver, supply 24 VDC on pin C referred to pin B: Enable input signal allows to enable/disable the current supply to the solenoid, without removing the electrical power supply to the driver; it is used to maintain active the communication and the other driver functions when the valve has to be disabled. This condition does not comply with European Norms EN13849-1 (ex EN954-1).

11.4 Option /Z

It provides, on the 12 pin main connector, the following additional features:

Enable Input Signal

To enable the driver, supply 24 VDC on pin 3 referred to pin 2: Enable input signal allows to enable/disable the current supply to the solenoid, without removing the electrical power supply to the driver; it is used to maintain active the communication and the other driver functions when the valve has to be disabled. This condition does not comply with European Norms EN13849-1 (ex EN954-1).

Fault Output Signal

Fault output signal indicates fault conditions of the driver (solenoid short circuits/not connected, reference signal cable broken for 4÷20mA input, etc.). Fault presence corresponds to 0 Vdc, normal working corresponds to 24 VDC (pin 11 referred to pin 2): Fault status is not affected by the Enable input signal

Power supply for driver's logics and communication - only for TES

Separate power supply (pin 9,10) allow to cut solenoid power supply (pin 1,2) while maintaining active diagnostics, USB and fieldbus communication. A safety fuse is required in series to each driver power supply: 500 mA fast fuse.

11.5 Options /C - only for SP, SF, SL

Option /C is available to connect pressure (force) transducers with 4 ÷ 20 mA current output signal, instead of the standard $\pm 10 \text{ V}$.

Input signal can be reconfigured via software selecting between voltage and current, within a maximum range of $\pm 10 \text{ V}$ or $\pm 20 \text{ mA}$.

11.6 Possible combined options

For SN: /FI, /IQ and /IZ

For SP, SF, SL: /CI

12 ELECTRONIC CONNECTIONS AND LEADS

12.1 Main connector signals - 7 pin - standard, /F and /Q options (A1)

PIN	Standard	/Q	/F	TECHNICAL SPECIFICATIONS	NOTES
A	V+			Power supply 24 Vdc Rectified and filtered: $V_{RMS} = 20 \div 32 V_{MAX}$ (ripple max 10 % Vpp)	Input - power supply
B	V0			Power supply 0 Vdc	Gnd - power supply
C	AGND		AGND	Analog ground	Gnd - analog signal
		ENABLE		Enable (24 Vdc) or disable (0 Vdc) the valve, referred to V0	Input - on/off signal
D	Q_INPUT+			Flow reference input signal: $\pm 10 Vdc / \pm 20 mA$ maximum range Defaults are $\pm 10 Vdc$ for standard and $4 \div 20 mA$ for /I option	Input - analog signal Software selectable
E	INPUT-			Negative reference input signal for Q_INPUT+	Input - analog signal
F	Q_MONITOR referred to:			Flow monitor output signal: $\pm 10 Vdc / \pm 20 mA$ maximum range Defaults are $\pm 10 Vdc$ for standard and $4 \div 20 mA$ for /I option	Output - analog signal Software selectable
	AGND	V0	FAULT	Fault (0 Vdc) or normal working (24 Vdc)	Output - on/off signal
G	EARTH			Internally connected to the driver housing	

12.2 Main connector signals - 12 pin - /Z option and SP, SF, SL (A2)

PIN	TEB-SN /Z	TES-SN /Z	TES-SP, SF, SL Fieldbus	NP	TECHNICAL SPECIFICATIONS	NOTES
1	V+				Power supply 24 Vdc Rectified and filtered: $V_{RMS} = 20 \div 32 V_{MAX}$ (ripple max 10 % Vpp)	Input - power supply
2	V0				Power supply 0 Vdc	Gnd - power supply
3	ENABLE referred to:				Enable (24 Vdc) or disable (0 Vdc) the valve	Input - on/off signal
	V0	VL0	VL0	V0		
4	Q_INPUT+				Flow reference input signal: $\pm 10 Vdc / \pm 20 mA$ maximum range Defaults are $\pm 10 Vdc$ for standard and $4 \div 20 mA$ for /I option	Input - analog signal Software selectable
5	INPUT-				Negative reference input signal for Q_INPUT+ and F_INPUT+	Input - analog signal
6	Q_MONITOR referred to:				Flow monitor output signal: $\pm 10 Vdc / \pm 20 mA$ maximum range Defaults are $\pm 10 Vdc$ for standard and $4 \div 20 mA$ for /I option	Output - analog signal Software selectable
	AGND	VL0	VL0	V0		
7	AGND				Analog ground	Gnd - analog signal
		NC			Do not connect	
8			F_INPUT+		Pressure/Force reference input signal: $\pm 10 Vdc / \pm 20 mA$ maximum range Defaults are $\pm 10 Vdc$ for standard and $4 \div 20 mA$ for /I option	Input - analog signal Software selectable
	R_ENABLE				Repeat enable, output repeter signal of enable input, referred to V0	Output - on/off signal
9		NC			Do not connect	
		VL+			Power supply 24 Vdc for driver's logic and communication	Input - power supply
10			D_IN0		Multiple pressure/force PID selection, referred to V0	Input - analog signal
	NC				Do not connect	
11		VL0			Power supply 0 Vdc for driver's logic and communication	Gnd - power supply
			D_IN1		Multiple pressure/force PID selection (not available for SF), referred to V0	Input - on/off signal
12	FAULT referred to:				Fault (0 Vdc) or normal working (24 Vdc)	Output - on/off signal
	V0	VL0	VL0	VL0		
PE	EARTH				Internally connected to the driver housing	

Note: do not disconnect VL0 before VL+ when the driver is connected to PC USB port.

12.3 Communications connectors (B) - (C)

(B) USB connector - M12 - 5 pin always present		
PIN	SIGNAL	TECHNICAL SPECIFICATION (1)
1	+5V_USB	Supply for external USB Flash Drive
2	ID	USB Flash Drive identification
3	GND_USB	Signal zero data line
4	D-	Data line -
5	D+	Data line +

(C1) (C2) BP fieldbus execution, connector - M12 - 5 pin		
PIN	SIGNAL	TECHNICAL SPECIFICATION (1)
1	+5V	Termination supply signal
2	LINE-A	Bus line (high)
3	DGND	Data line and termination signal zero
4	LINE-B	Bus line (low)
5	SHIELD	

Notes: (1) shield connection on connector's housing is recommended

(C1) (C2) BC fieldbus execution, connector - M12 - 5 pin		
PIN	SIGNAL	TECHNICAL SPECIFICATION (1)
1	CAN_SHLD	Shield
2	not used	(C1) - (C2) pass-through connection (2)
3	CAN_GND	Signal zero data line
4	CAN_H	Bus line (high)
5	CAN_L	Bus line (low)

(C1) (C2) EH, EW, EI fieldbus execution, connector - M12 - 4 pin		
PIN	SIGNAL	TECHNICAL SPECIFICATION (1)
1	TX+	Transmitter
2	RX+	Receiver
3	TX-	Transmitter
4	RX-	Receiver
Housing	SHIELD	

(2): pin 2 can be fed with external +5V supply of CAN interface

12.4 Remote pressure/force transducer connector - M12 - 5 pin - only for SP, SF, SL (D)

PIN	SIGNAL	TECHNICAL SPECIFICATION	Single transducer (1)		Double transducers (1)	
			Voltage	Current	Voltage	Current
1	VF +24V	Power supply +24Vdc	Connect	Connect	Connect	Connect
2	TR1	1st signal transducer: $\pm 10 Vdc / \pm 20 mA$ maximum range, software selectable Defaults are $\pm 10 Vdc$ for standard and $4 \div 20 mA$ for /C option	Connect	Connect	Connect	Connect
3	AGND	Common GND for transducer power and signals	Connect	/	Connect	/
4	TR2	2nd signal transducer: $\pm 10 Vdc / \pm 20 mA$ maximum range, software selectable Defaults are $\pm 10 Vdc$ for standard and $4 \div 20 mA$ for /C option	/	/	Connect	Connect
5	NC	Not connect	/	/	/	/

Note (1) single/double transducer configuration is software selectable

12.5 Connections layout

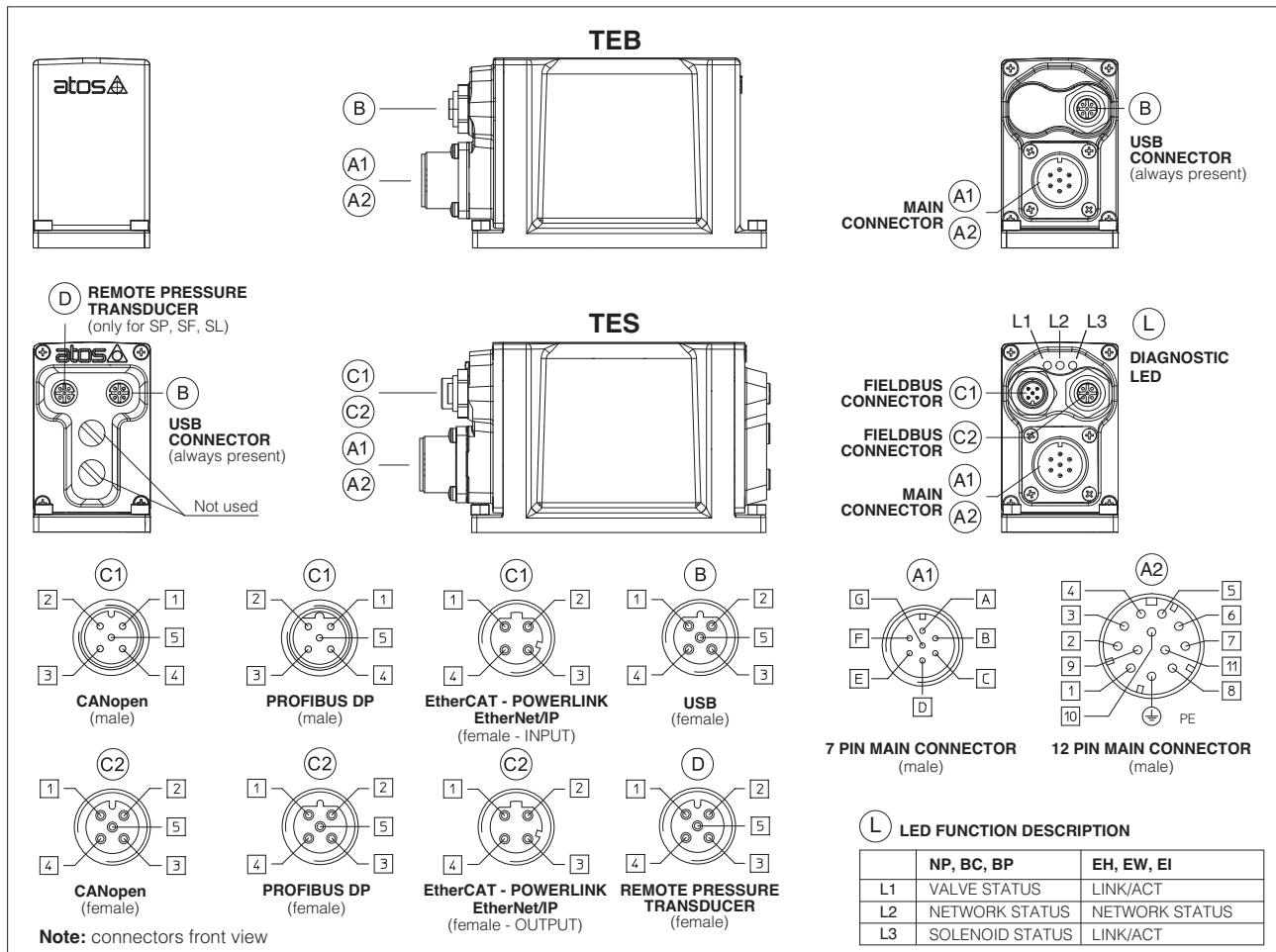

13 CONNECTORS

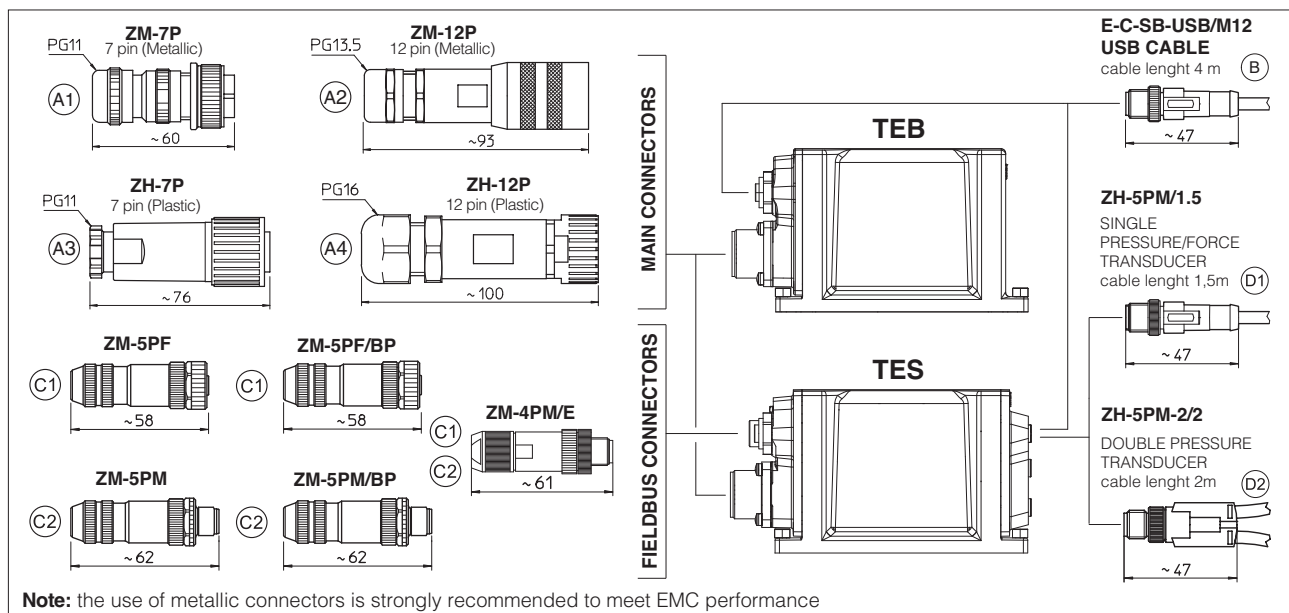

14 MODEL CODES OF MAIN CONNECTORS AND COMMUNICATION CONNECTORS - to be ordered separately

VALVE VERSION	TEB TES	TEB /Z TES /Z	BC - CANopen	BP - PROFIBUS DP	EH - EtherCat EW - POWERLINK EI - EtherNet/IP	P/Q controls SP, SL, SF
CONNECTOR CODE	ZM-7P (A1) ZH-7P (A3)	ZM-12P (A2) ZH-12P (A4)	ZM-5PF (C1) ZM-5PM (C2)	ZM-5PF/BP (C1) ZM-5PM/BP (C2)	ZM-4PM/E (C1) ZM-4PM/E (C2)	ZH-5PM/1.5 (1) (D1) ZH-5PM-2/2 (2) (D2)
PROTECTION DEGREE	IP67					
DATA SHEET	GS208, GS210, GS212, K500					

only for TES

(1) only for SP or SL

(2) only for SF

15 PROGRAMMING TOOLS - see table **GS500**

Valve's functional parameters and configurations, can be easily set and optimized using Atos E-SW programming software connected via USB port to the digital driver. For fieldbus versions, the software permits valve's parameterization through USB port also if the driver is connected to the central machine unit via fieldbus.

The software is available in different versions according to the driver's options:

E-SW-BASIC support: NP (USB) PS (Serial) IR (Infrared)

E-SW-FIELDBUS support: BC (CANopen) BP (PROFIBUS DP) EH (EtherCAT)
EW (POWERLINK) EI (EtherNet/IP)

E-SW-*/PQ support: valves with SP, SF, SL alternated control (e.g. E-SW-BASIC/PQ)

WARNING: drivers USB port is not isolated!

The use of isolator adapter is highly recommended for PC protection (see table **GS500**)

USB connection

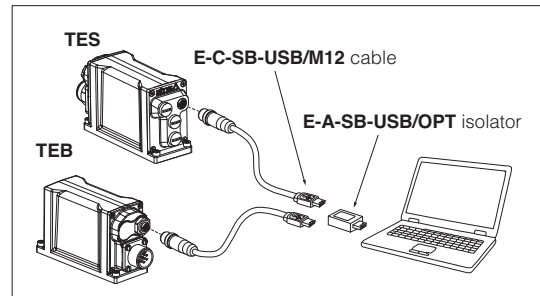

16 INSTALLATION DIMENSIONS [mm]

DHZO-TEB, DHZO-TES

ISO 4401: 2000

Mounting surface: 4401-03-02-0-05 (see table P005)

(for /Y surface 4401-03-03-0-05 without X port)

Fastening bolts: 4 socket head screws M5x50 class 12.9

Tightening torque = 8 Nm

Seals: 4 OR 108; 1 OR 2025

Diameter of ports A, B, P, T: Ø 7,5 mm (max)

Diameter of port Y: Ø = 3,2 mm (only for /Y option)

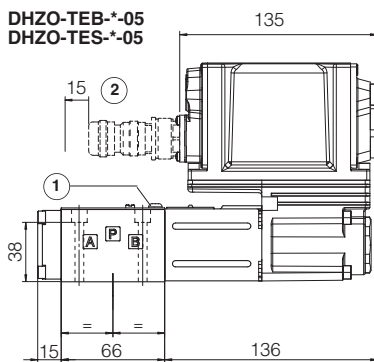

Mass: 2,3 kg

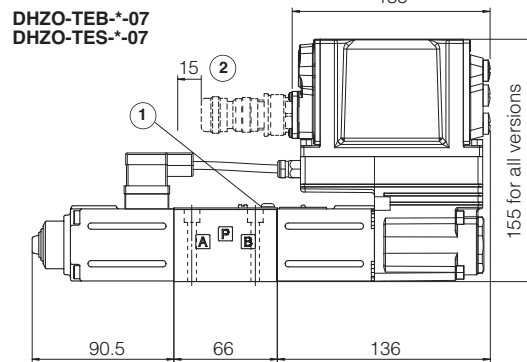
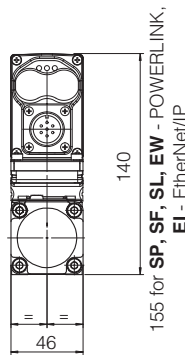

Mass: 3,1 kg

DKZOR-TEB, DKZOR-TES

ISO 4401: 2000

Mounting surface: 4401-05-04-0-05 (see table P005)

(for /Y surface 4401-05-05-0-05 without X port)

Fastening bolts: 4 socket head screws M6x40 class 12.9

Tightening torque = 15 Nm

Seals: 5 OR 2050; 1 OR 108

Diameter of ports A, B, P, T: Ø 11,2 mm (max)

Diameter of port Y: Ø = 5 mm (only for /Y option)

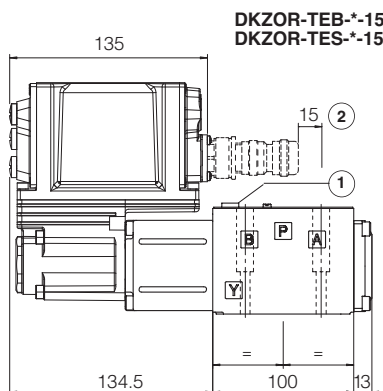

Mass: 4,3 kg

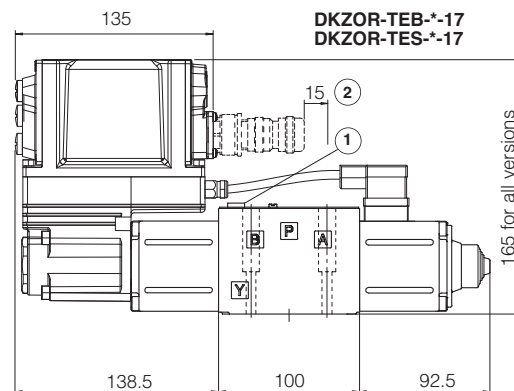
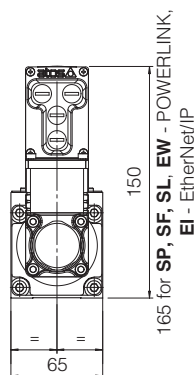

Mass: 5,0 kg

① = Air bleed off

② = Space to remove the 7 or 12 pin main connector. For main and communication connectors see section 13, 14